



PRESSERV

Making things last

Utilisation of PIB Coating for long life protection of pipework and structural steel

Cost Efficient, Simple and Fast Corrosion Mitigation



sealforlife.com

ICorr Aberdeen Webinar – PIB Based Coatings

Reducing the environmental footprint for surface preparation and coating

26th April, 2022

Presented by: Dinko Cudic and Stuart Rennie

 **SEALFORLIFE**
Industries

Selecting a coating system

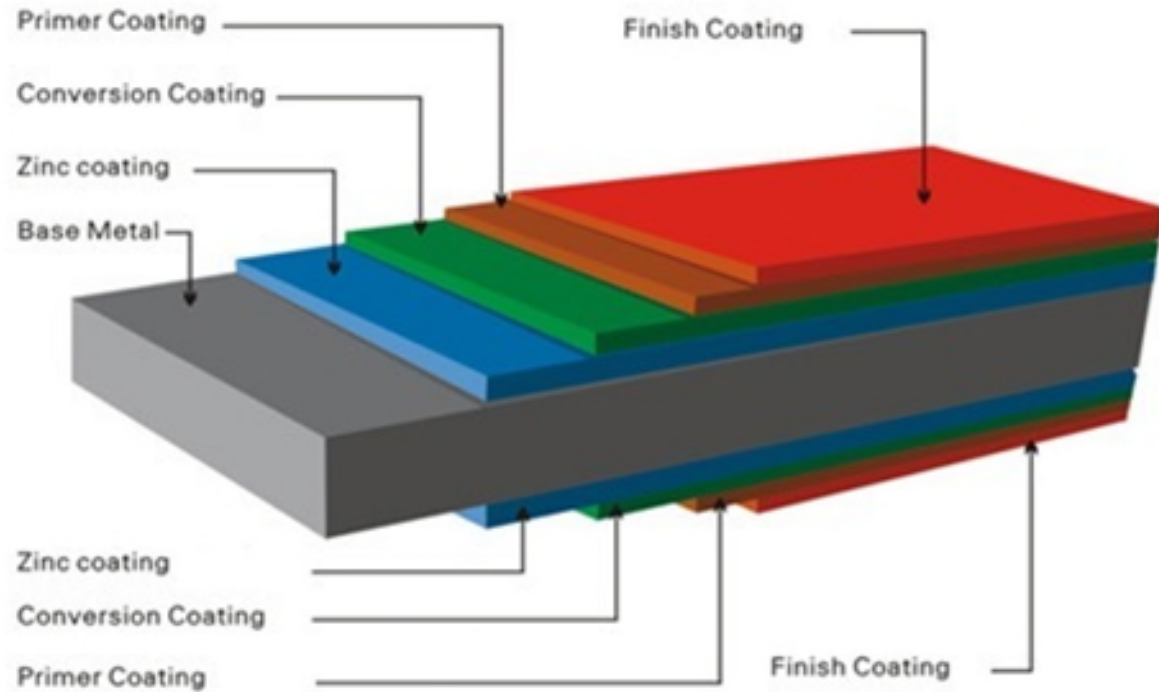

Anti-corrosive but also UV resistance...

Surface preparation and anchor profile

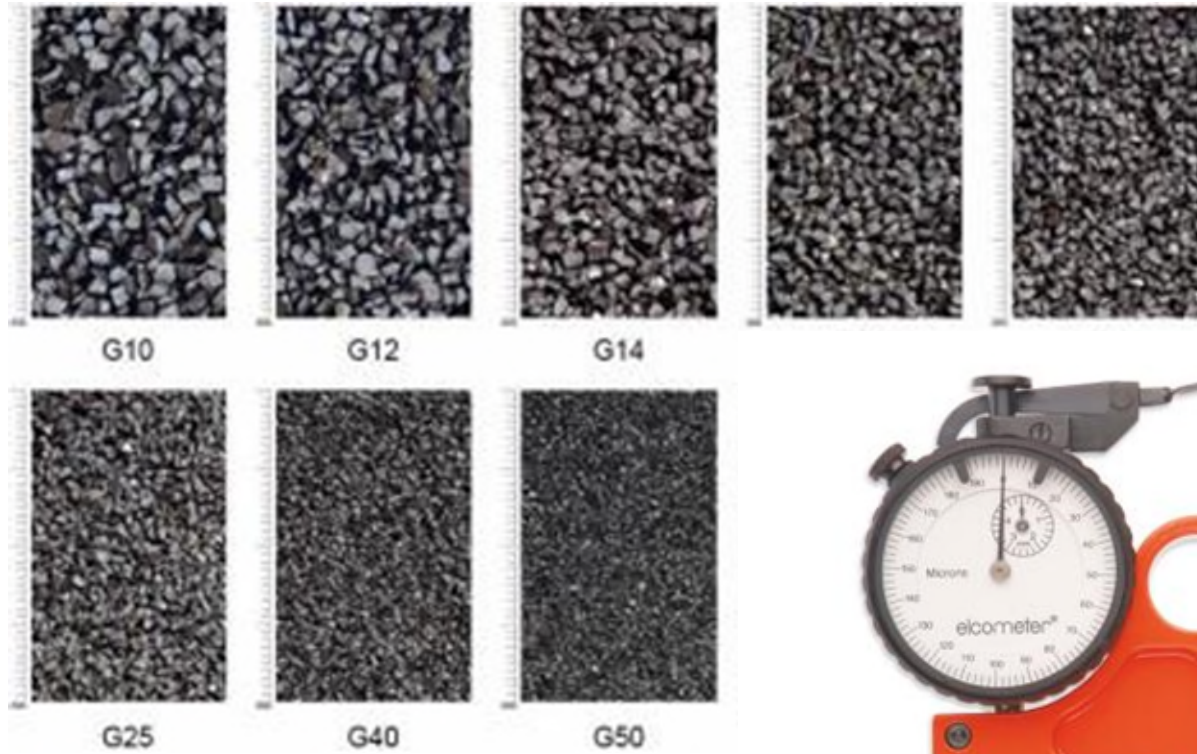

Roughness or anchor profile...



Surface cleanliness

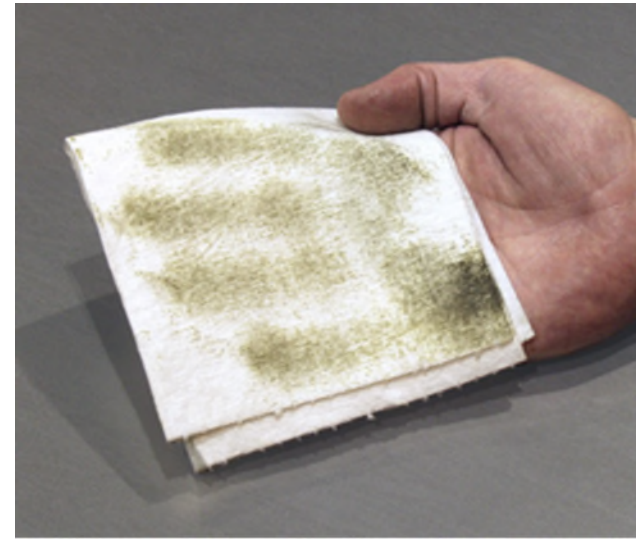

Chloride and surface contaminants...

Atmospheric conditions

Ambient and surface temperature, humidity and dew point



Wind speed and coating thickness



Overspray...

Equipment

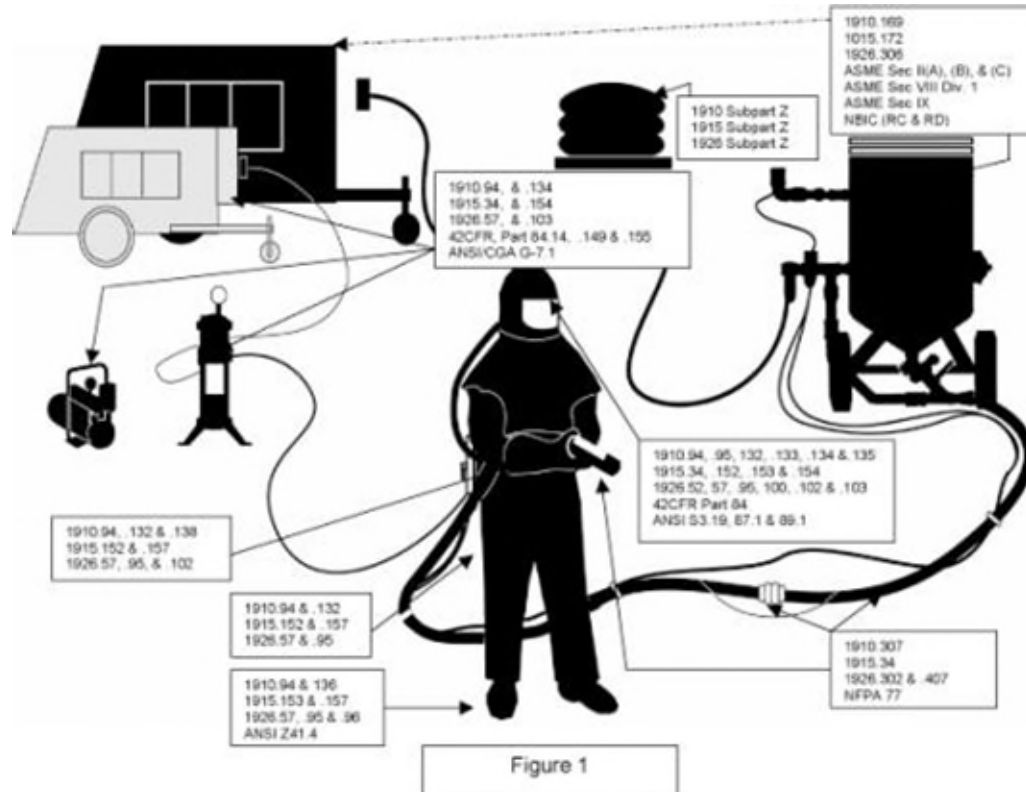

Heavy equipment backed by compressors...

Equipment

- Not easy to maintain the right angles



Coating technique

- **Maintaining thickness**
- **Workmanship is of essence**



Applicator safety

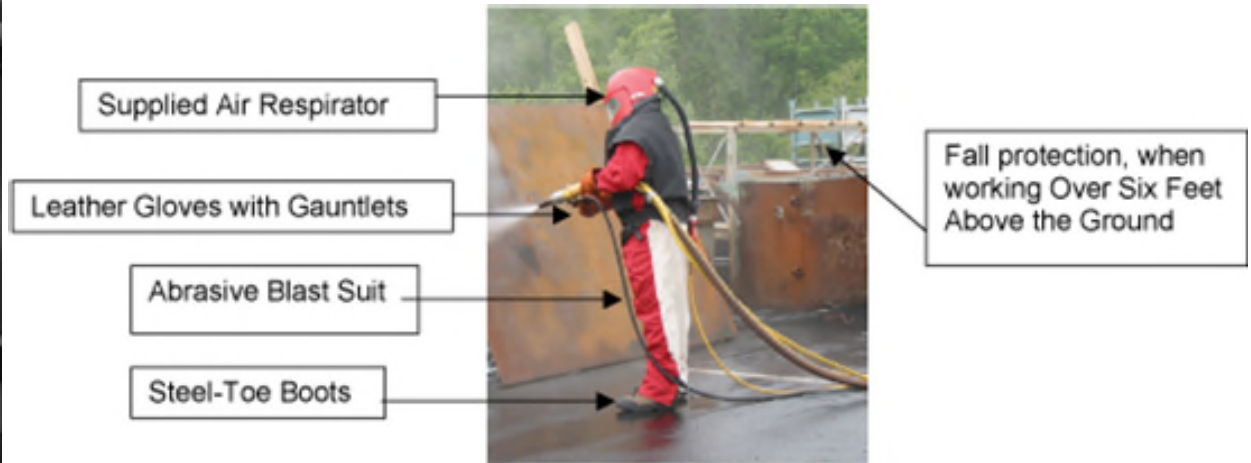

Work environment



Final inspection

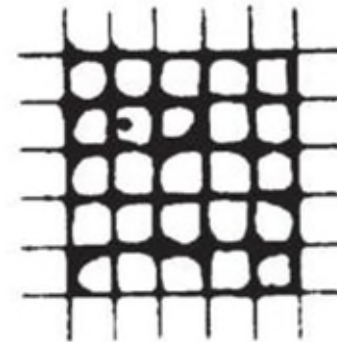
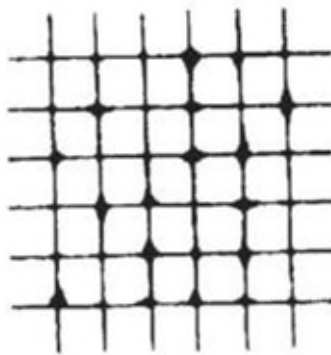

Effects of abrasive blasting

- Mining (garnet)
- Transport
- Storage and handling
- Safety hazard
- Waste creation
- Filtering
- **Disposal**

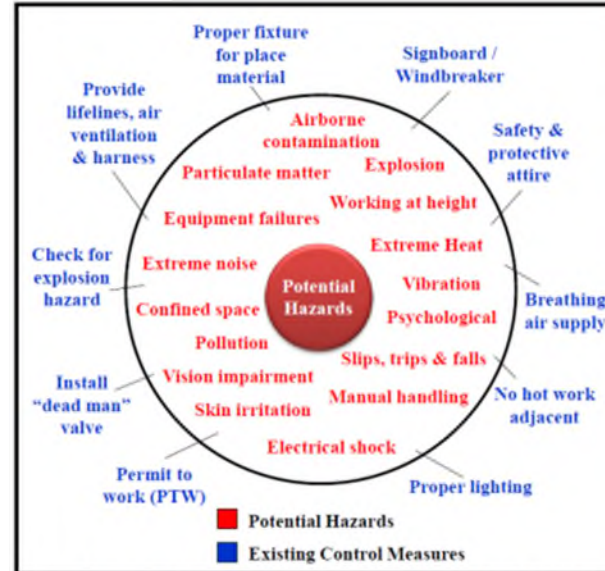

Figure 3: Comparison between potential hazards and existing control measures



Effects of coating

- VOCs
- Heavy metals – lead, chromate
- Overspray
- Health
- Equipment cleaning
- Contaminated buckets
- Recycling energy
- **Disposal**



Can it be as easy as this?

- **Minimum surface preparation to St2 / St3**



sealforlife.com

Re defining corrosion prevention

Stopaq – or STOP AQUA

Coating engineering requirements

- Minimum surface preparation requirement – St2
- No surface roughness required – dispersive adhesion mechanism
- Adheres to most surfaces, non coated or coated
- No corrosion under creep, impervious to oxygen and water
- Predefined coating thickness
- No VOCs, chemical exposure hours
- Harmless to the environment
- Emission free surface preparation and application contributor
- 30-year design life – compound does not dry / UV resistance / impact resistance
- Minimum waste management solution



ONE COMPANY INNOVATIVE TECHNOLOGIES ULTIMATE PROTECTION

Approach

Health, Safety, Environment and Sustainability



- Safety of people
 - No Hazardous components or chemicals used
 - No VOCs
 - Storage – non-flammable (no toxic fumes)
 - No hazardous equipment used for application



- Environmental impact
 - Nonhazardous materials
 - No emission equipment



- Economic aspect
 - Durability and lifetime performance design of minimum 30 years with zero maintenance intervals

Polyisobutene

Designed to extend asset lifetime 30+ years

To stop corrosion

- Water, water vapor and gas impermeability
- Tacky even at low temperatures, both glass like and porous surfaces
- Creeps into pores and adheres at molecular level – dispersive
- High electrical resistance

To make is safe

- No smell, no evaporation of VOCs
- Skin irritant-free material
- Food industry approved
- Medical safe
- Kosher and Halaal

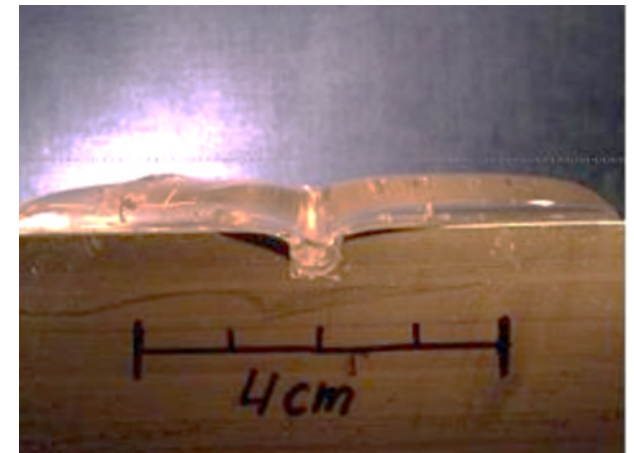
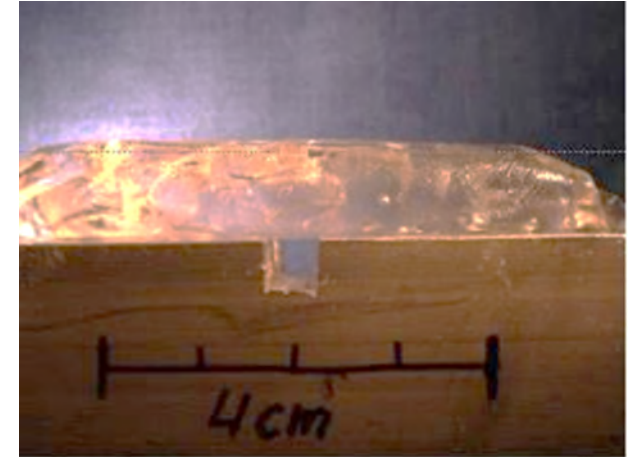

The beginning

Compound pumped onto pipes

- Compound
- Netting
- Backing
- Mechanical protection



The evolution

Bringing all the components into one in 1996



Systems selection

Pipework



Structural



Paste, putty, filler



Market Segmentation

One technology covering multiple applications

- Buried pipes and components
- Offshore / Onshore field joints
- Atmospheric
- Automated field applied systems (FAST)
- Corrosion Under Insulation
- Condensing Lines – wet substrate
- Splash Zone – submerged
- Insulation (sealing)
- Casing Filler
- Paintable - Basecoat
- Coating Repair Patch - pre pigmented solutions
- Sealing and waterproofing

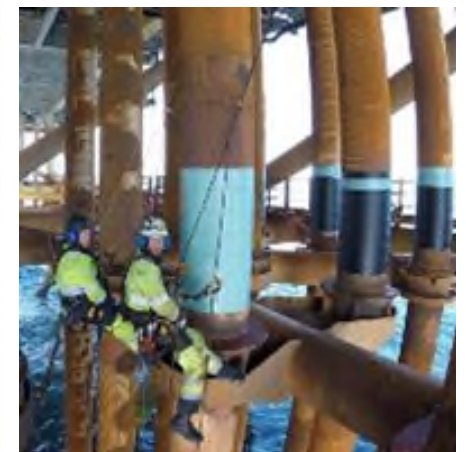

Market segment	Standards	Solution	Items
Underground (buried)	ISO 21809-3	Wrappingband CZ, CZH, CZHT + Outerwrap + OGS (Optional)	Pipes and components
Offshore Field Joints (submerged)	ISO 21809-3	Wrappingband CZ, CZH, CZHT + Outerwrap + OGS (Optional)	Pipes and components
Atmospheric	ISO 12944	Wrappingband CZ, CZH, CZHT + Outerwrap + OGS (Optional)	Pipes and components
Atmospheric Coatable	ISO 12944	Wrappingband EZ, EZR / Basecoat H, HT + Topcoat	Structural
Atmospheric – pre pigmented	ISO 12944	SC coating repair patches	Structural
Corrosion Under Insulation	ISO 19277	Wrappingband CZ, CZH, CZHT + Outerwrap	Pipes
Condensing Lines - UG/Atmospheric	ISO XXXX	Wrappingband CL + Outerwrap + OGS (Optional)	Pipes
Wet Substrate - Splash Zone	ISO 18797-2	Wrappingband SZ (WSH) + Intermediate + OGS Wrappingband CZ, CZH, CZHT + Outerwrap + OGS (Optional)	Pipes and conductors (tubular objects)
Insulation & Cladding (sealing)	ISO 17738-1	Aluclad Insulwrap	Cladding seal - external Insulation seal
Corrosion prevention automated (FAST)	ISO 21809-1	Basecoat FAST + Polyurea / GRE / Outerwrap	Pipes, piles
Casing Filler	ISO 16440	Casing filler	Casings
Sealing and waterproofing	various	Aquastop 2100 Basecoat	Wall penetrations Roof, Internal lining



Buried solutions

From compound to steel to a “wrap” applied coating

Pipelines



Saudi Arabia – since year 2000

Flanges

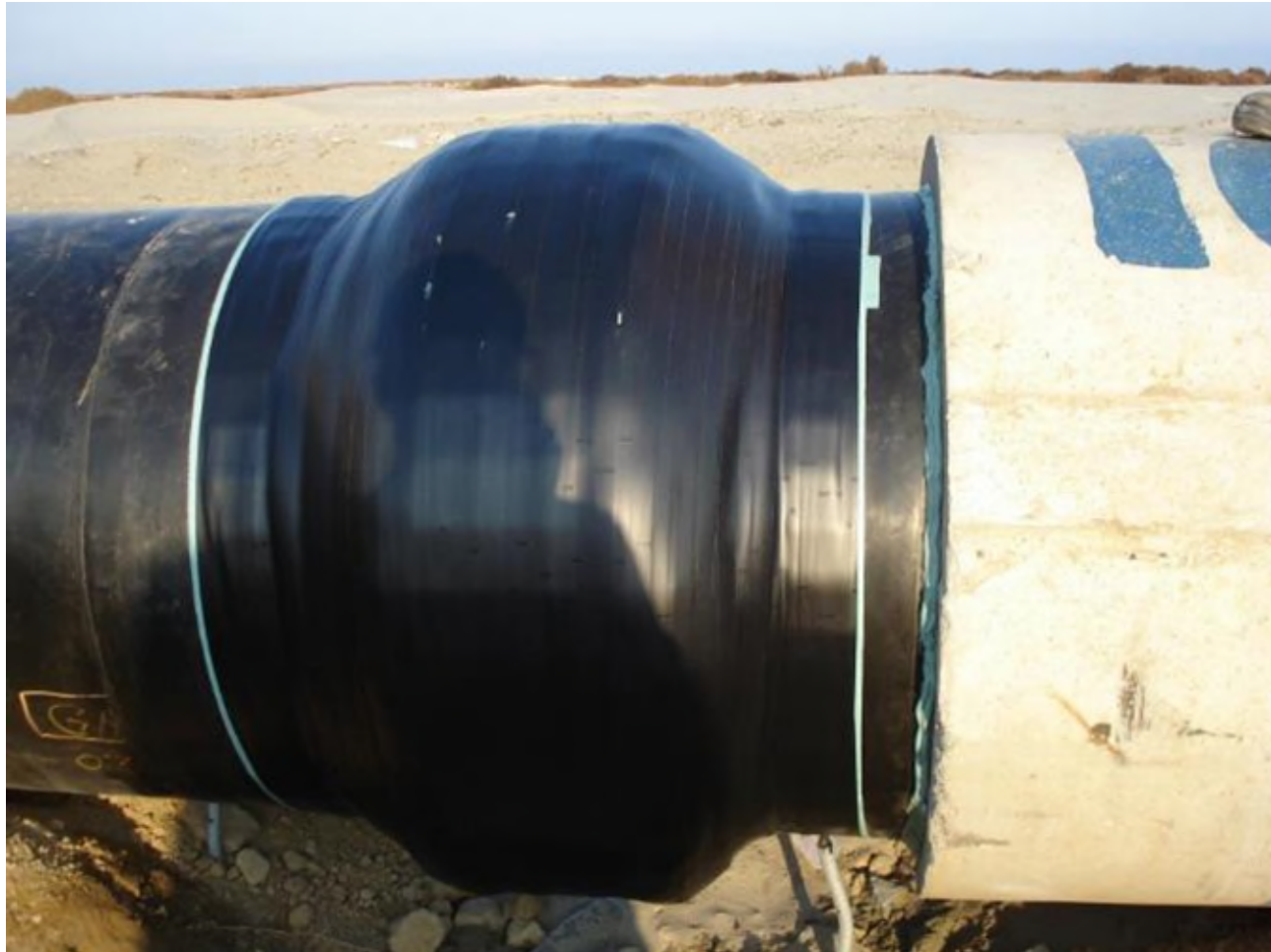

Flanges and fittings

Wrappingband and putty used to smooth out bolted parts and smooth out the edges



Pipe supports

Rigid, extra mechanical protection, used to distribute pin point pressure



Offshore Field Joints

Offshore field joint application with reduced cycle times



LNG / LPG storage tanks



LNG storage tanks

Coatable backing and polyurea system withstanding extreme expansion and contraction coefficients



Field applied automated system

Easy to assemble mobile coating unit on site for complete pipe coating



Atmospheric solutions

From compound to steel to a “wrap” applied coating

Stainless and duplex steel pipes

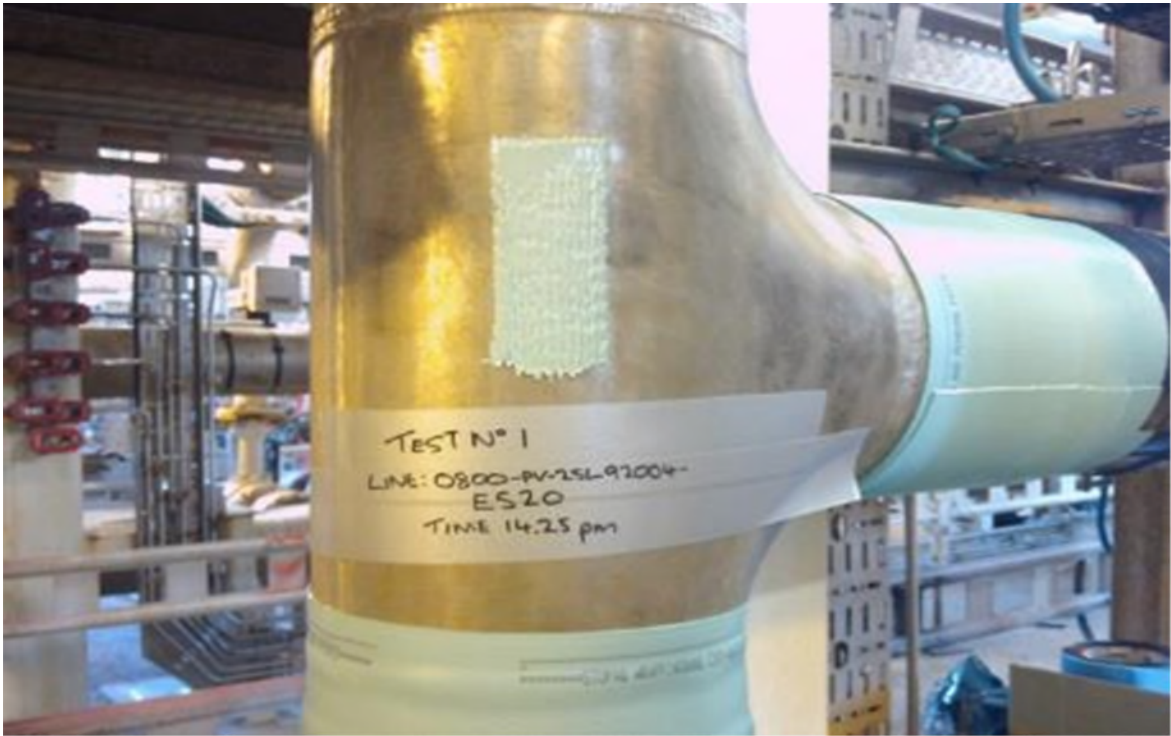

Walkways

Minimum scaffolding and habitat requirement



Conductor piles

Quick mobilisation and demobilisation accommodating to changing weather



Sound dampening of “noisy” pipes

Reducing vibrations and creating a safer environment for the operators



Flare booms

Minimum surface preparation requirements allow easy access

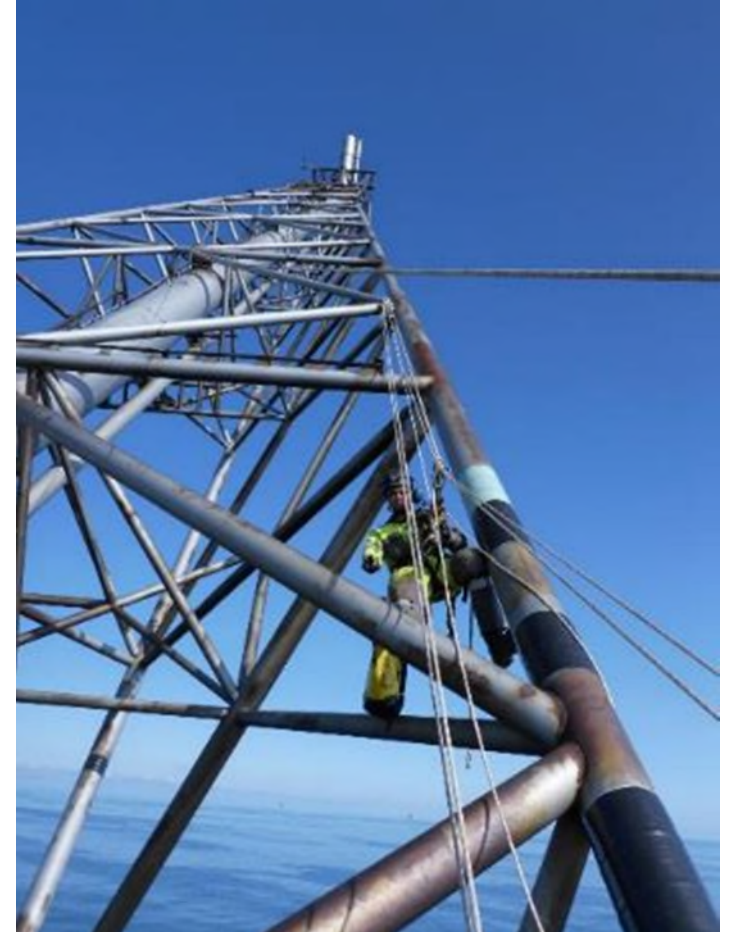
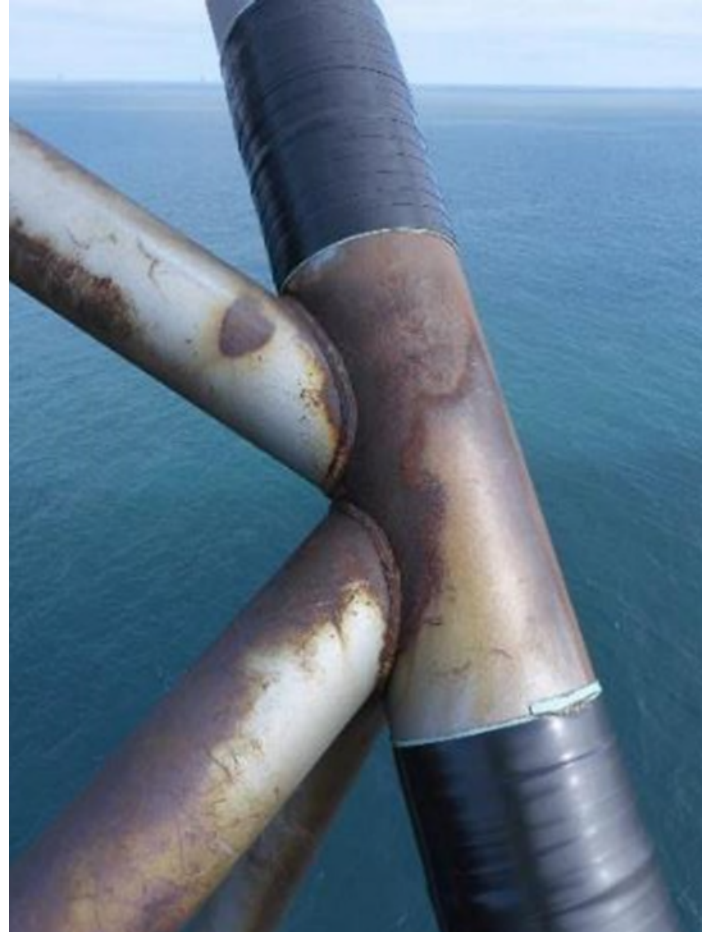

Structures – offshore accommodation block

Reduction in operations allows quieter application where people sleep and work



FPSO – flange encapsulation

Galvanic corrosion caused by use of stainless steel bolts on carbon steel flanges



Stopaq CUI solution – Front End Engineering Design

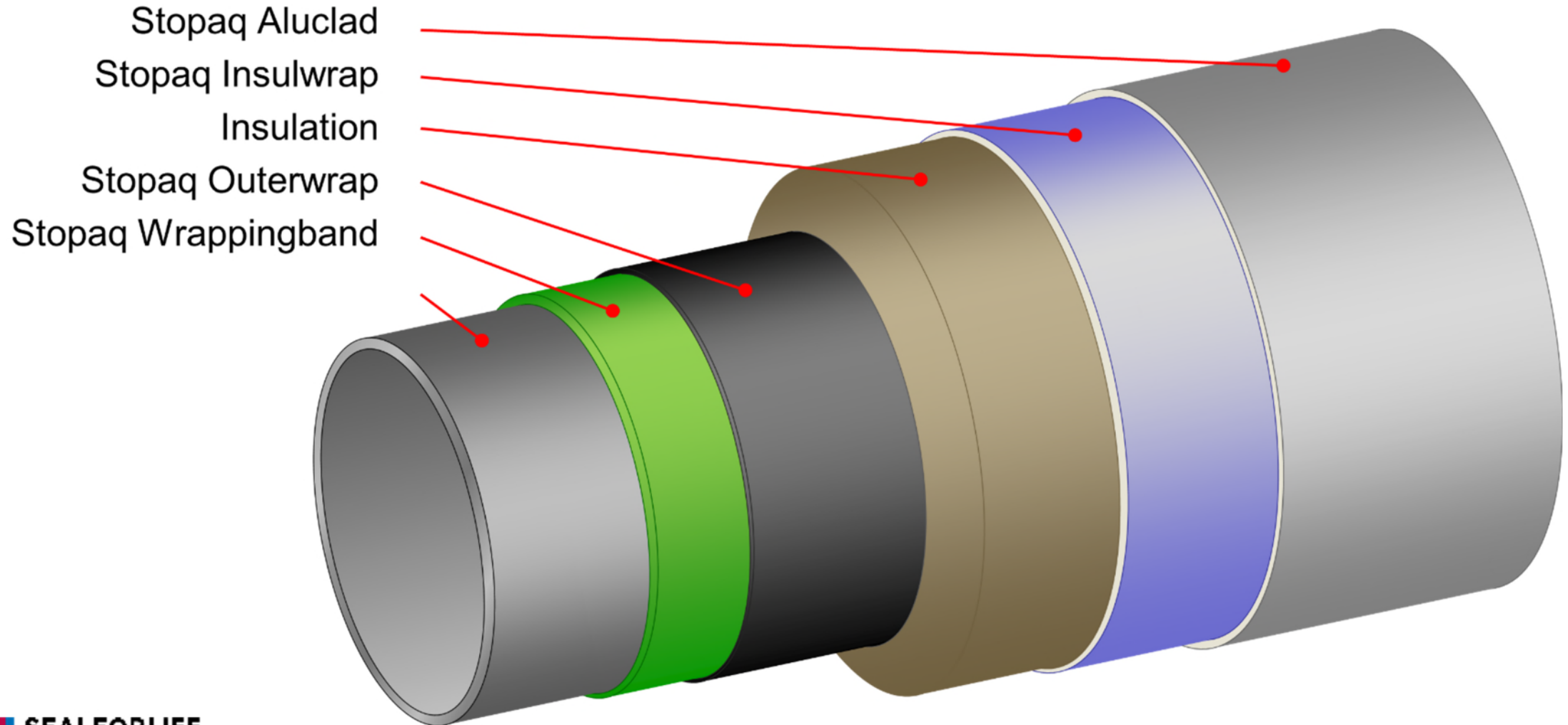

Under Insulation



Application without shut-down



Above Insulation

- InsulWrap
- AluClad

Sealing against rainfall
and humidity



EasyQuote – WIND

Coating repair solutions



Easy - Quote[®]

EasyQote product range in the Renewable Energy market

- EasyQote SC Patch grey and yellow
 - Atmospheric corrosion prevention and sealing solution
- EasyQote VE Paste
 - Mouldable material to fill up irregular shapes and sharp edges
- EasyQote VE Basecoat
 - Coatable corrosion prevention and sealing solution
- EasyQote WB Topcoat
 - Paint to be used over the EasyQote VE Basecoat



EasyQote use on wind turbines



- Rotor shaft groove
- Internal coating repair Basecoat
- External coating repair SC Patch
- Ladder stubs
- Platform tower repair
- Flange sealant
- ICCP connection
- Sealing of voids in the TP
- Sealing of internal sensors
- ICCP Flanges
- Slip Joint

Internal coating repair Basecoat

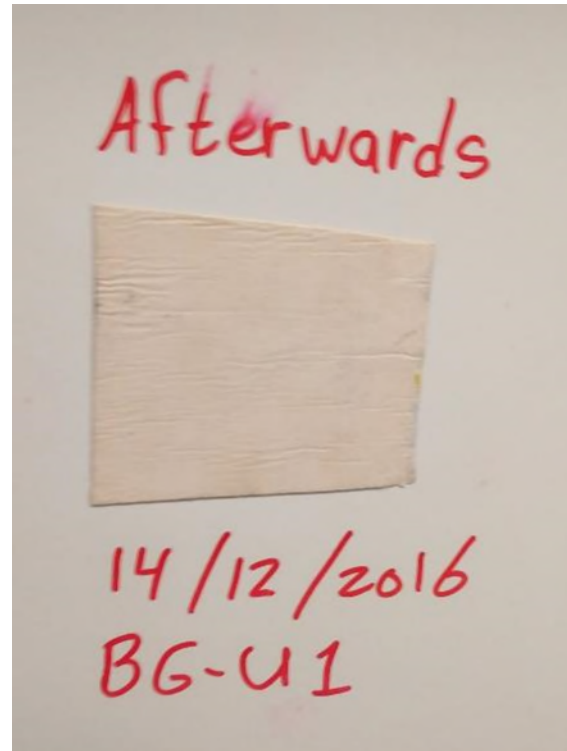

Sealing of internal sensors

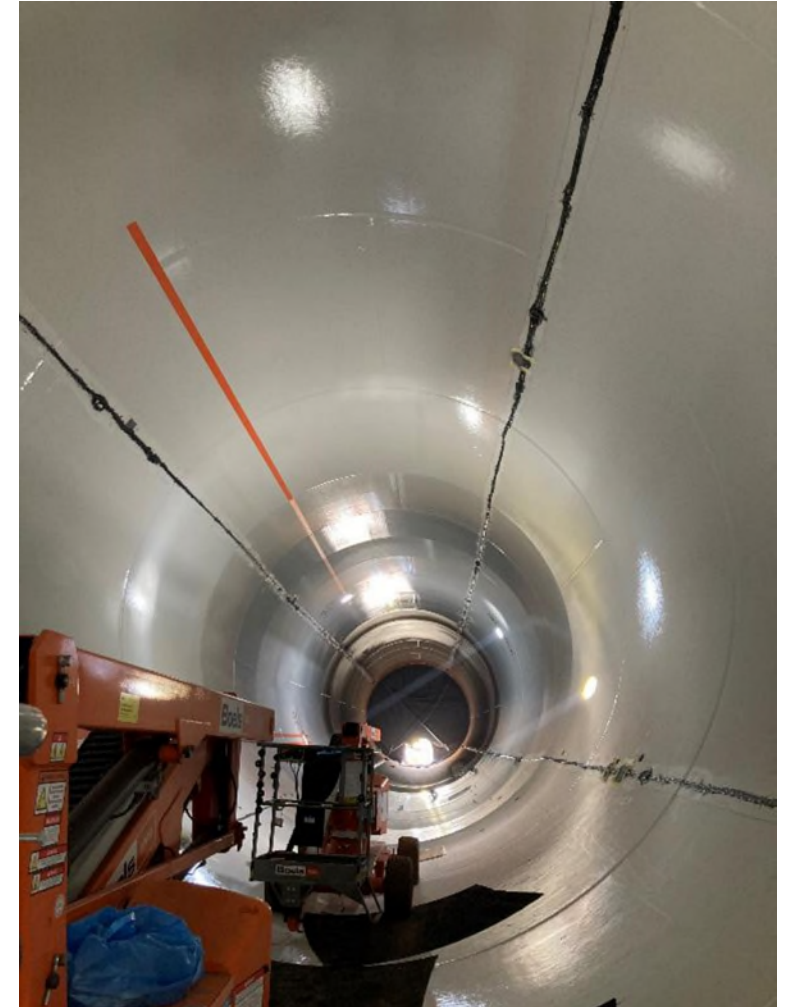
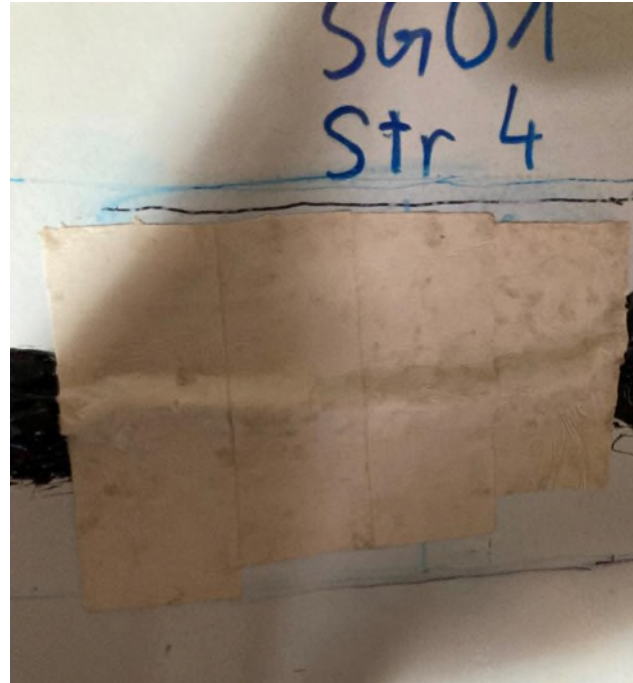
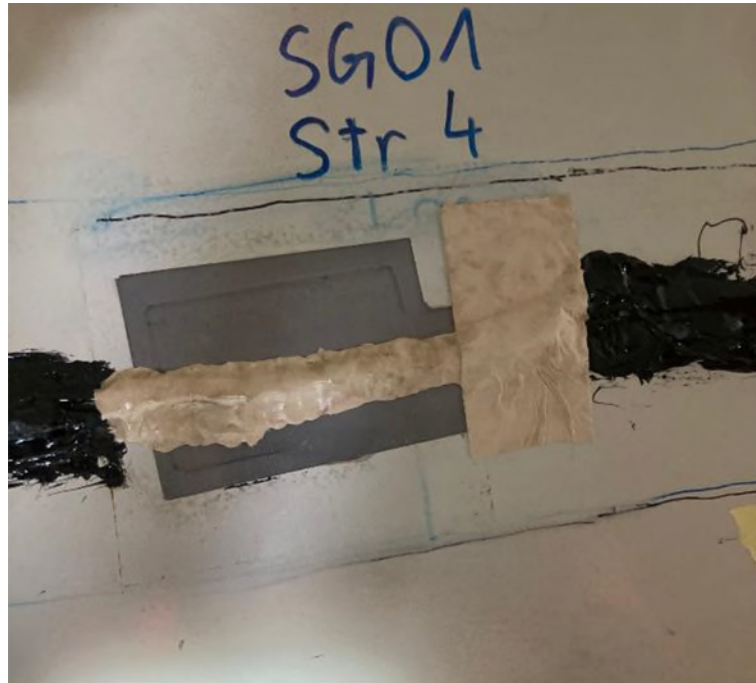
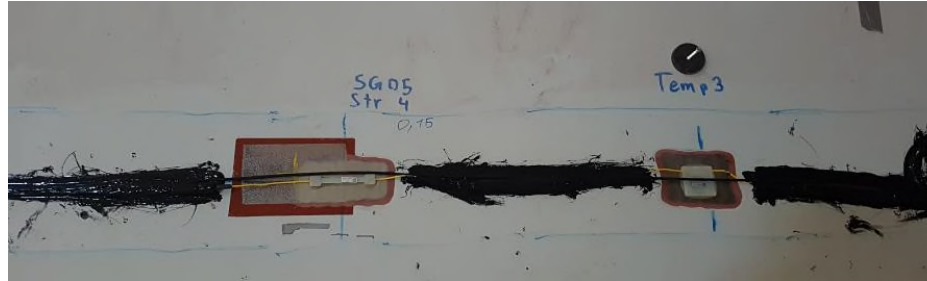

External coating repair SC Patch

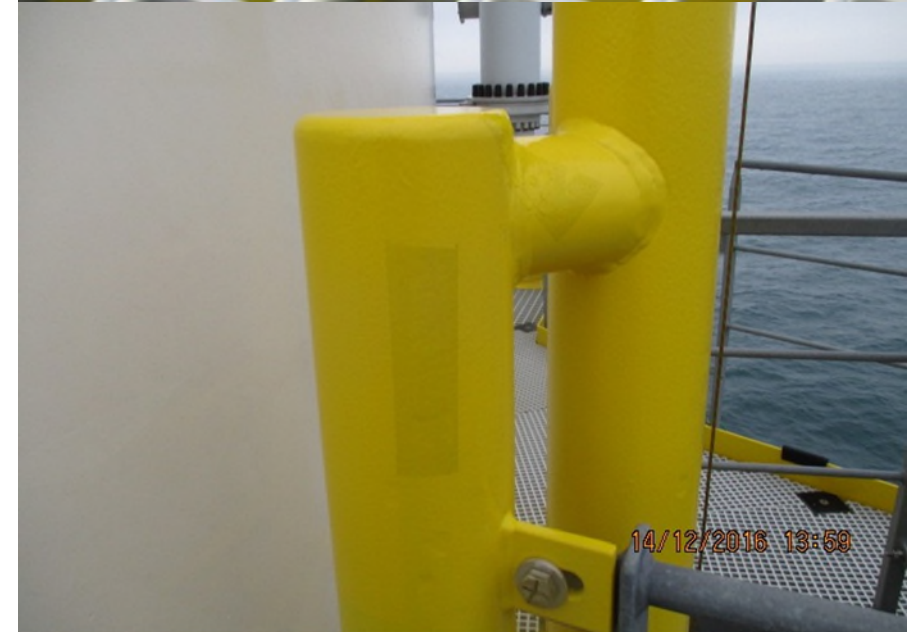

SC Patches after more than 5 years in offshore condition

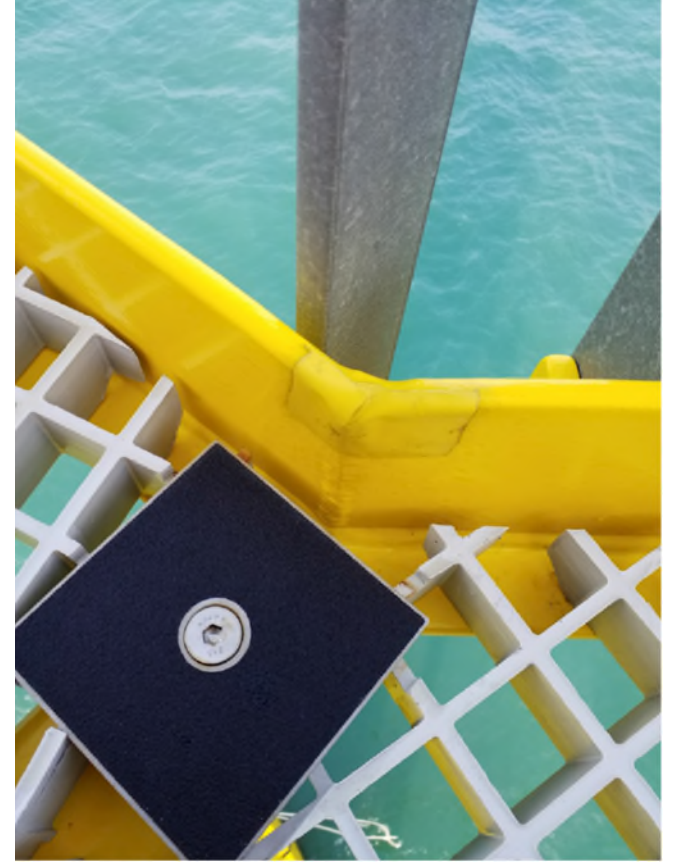

Ladder stubs



Flange sealant



Sealing of voids in the TP



ICCP connection



ICCP Flanges



Slip Joint

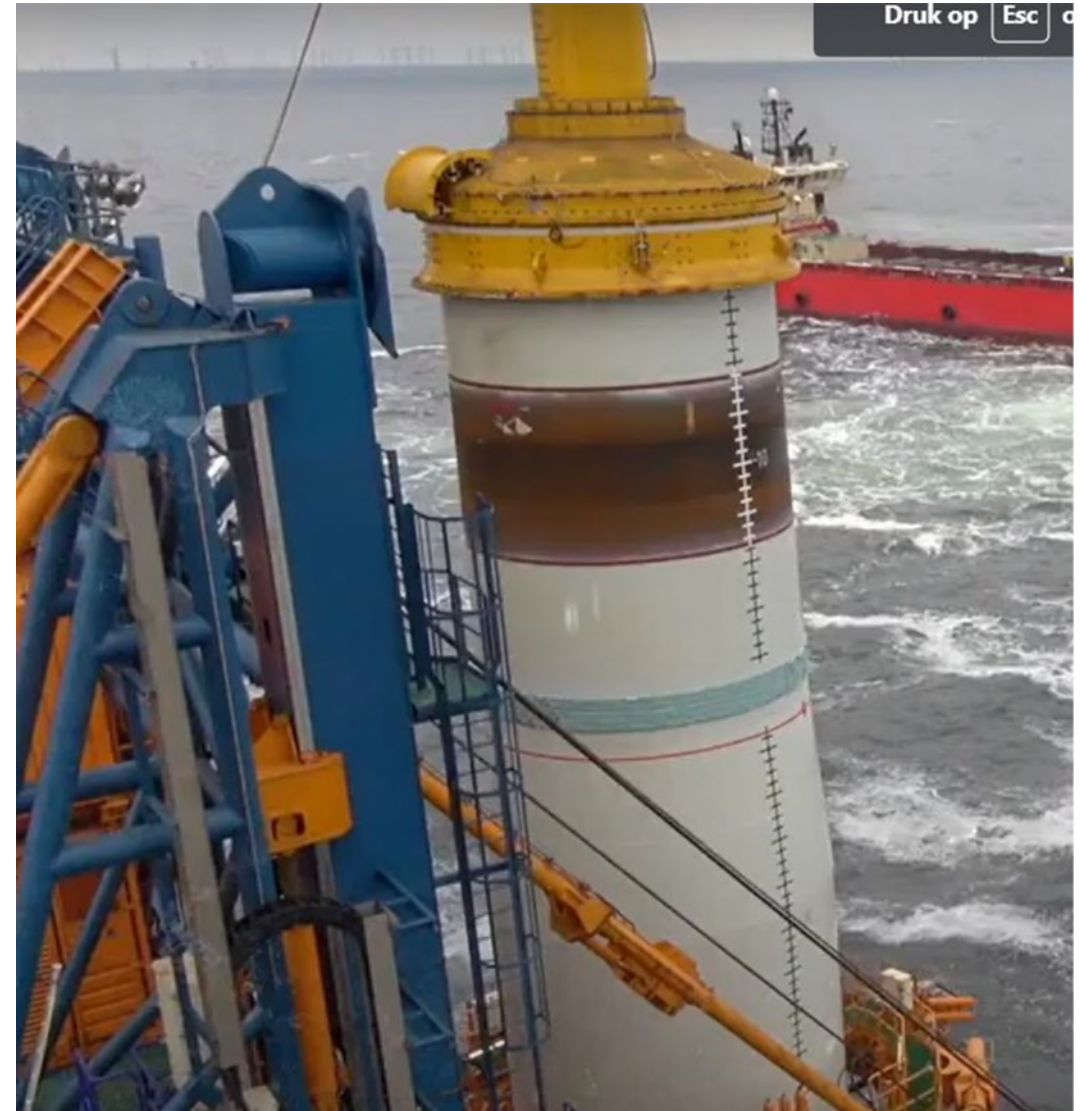

SC Patches on a sub stations



Sandwich panel sealing



Same application, different location: Electrical Wintrack towers

- EasyQote SC Patch as a sealant on a flanged connection





Easy-Qote[®]

Self Adhering Coating Solutions

One Company, Innovative Technologies, Ultimate Protection.

sealforlife.com

Beyond Corrosion Prevention

Impact on HSE

Surface preparation

Minimum requirements

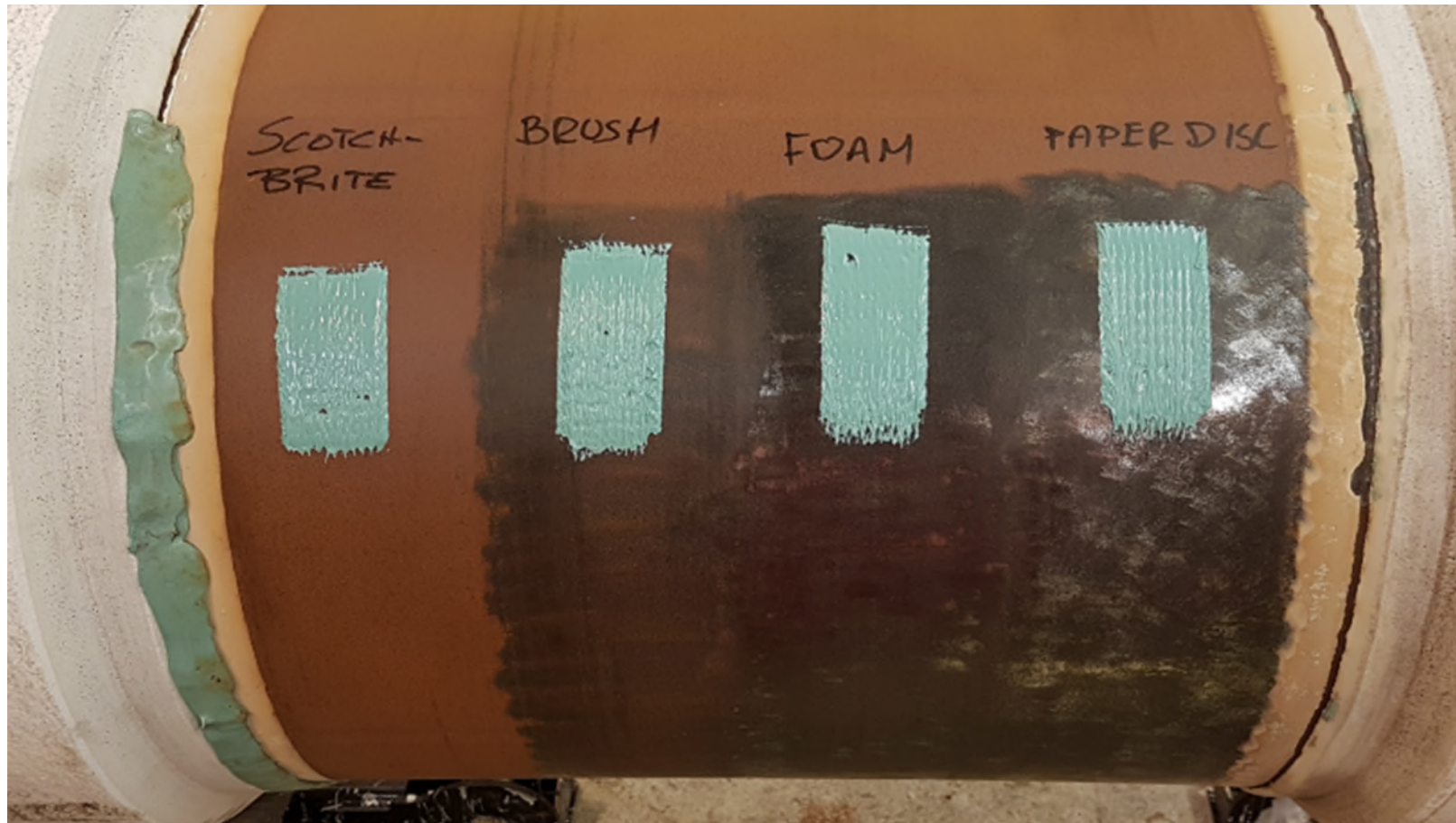

Cleanliness and adhesion check



No surface profile necessary

Workplace set up



Total cost of ownership

Evaluation of asset protection over time

- Evaluate performance of existing solutions, benefits / weakness
- Cost of solutions
- Cost of application / workmanship
- Cost of clean up / waste management
- Safety impact on applicators
- Waste management impact
- Emission (CO2) on environment
- Maintenance intervals
- Cost over time

Coating Vs Surface Preparation

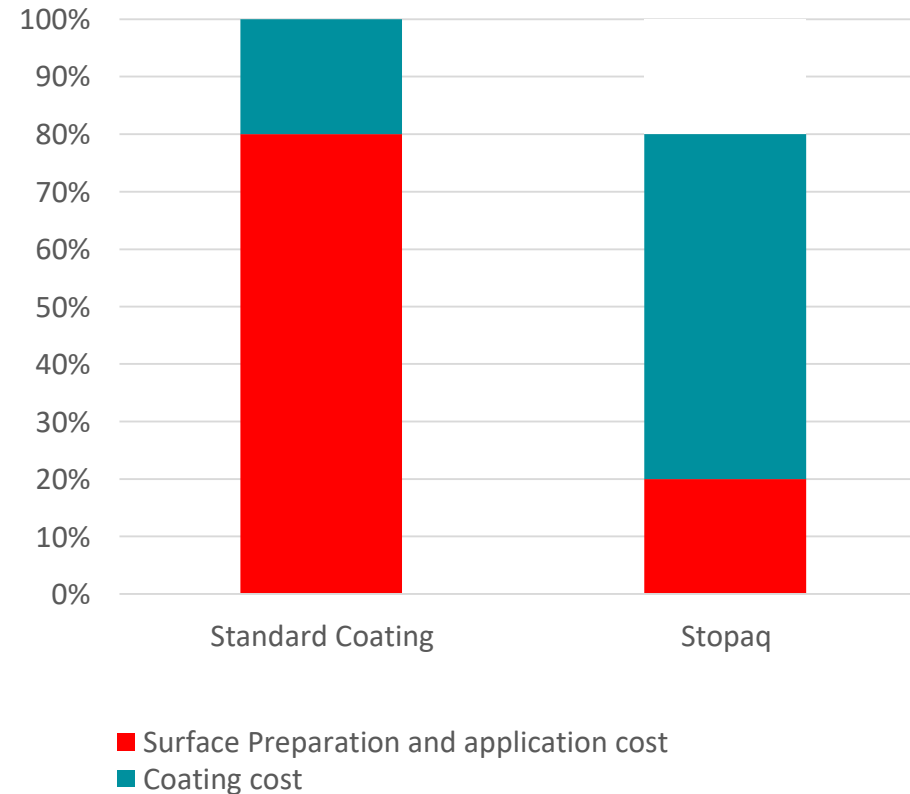

Client scheme evaluating Stopaq, 100m2



CRITERIA

BLAST & PAINT

STOPAQ

PERFORMANCE

- Waste
- Carbon emissions
- Safety
- Performance



- › Sourced from beach or mining in India or Australia; requires 22,000km transport by bulk carrier
- › Special transport (separate A+B)

- › EU/Norwegian origin
- › Regular cargo

- › Hazard labeled
- › Flammable
- › Allergic reaction to skin due to high chemical exposure
- › Requires respirator mask given the dust content and exposure

- › VOC / CMR free
- › Non-flammable
- › No chemical exposure
- › No dust content nor exposure

- › 10+ years maintenance interval
- › 24 months shelf life
- › 24-36 hours intervals between layers – system several days.

- › 30+ years maintenance interval
- › Unlimited shelf life
- › Hot or cold applied
- › Complete system in same day

>99%

Waste reduction

≥90%

Reduced carbon emissions

Non-hazardous material and exposure

3x

Extended maintenance interval

Conclusion:

Stopaq significantly minimizes the waste treatment and improve the environmental impact in project. Stopaq represent a higher performance and also brings safety benefits for our operators.

Cost comparison

Atmospheric Wrap / CUI / Paintable VS. Industrial Coatings

Comparison Paint vs. Stopaq on pipes/bend 550m2 - actual project							
Abrasive blasting and 3 layer epoxy system	Amount	Rate/cost	Sum	Stopaq System CZH +PVC White	Amount	Rate/cost	Sum
Surface Preperation, Garnet blasting SA 2 ^{1/2}	1100 hours	50€	55000€	Surface Preperation, HP wash/isopropanol ST 2 ^{1/2}	410 hours	50€	20625€
Coating 3 layer epoxy system.	450L	8€	3600€	Stopaq CZ Stopaq PVC Outerwrap	2 layer system	100€	55000€
Rental equipment: HP wash, compressor, blasting pot, vacum unit, hoses, HP gun.	63 days	250€	12600€	Rental equipment: HP wash	10 days	50€	5000€
Consumables: Fuel, Garnet, HSEQ equipent.	Fuel 630L Garnet 11 tonn Misc.	6300€ 5500€ 1000€	12800€	Consumables: Misc and HSEQ equipent.	Misc	700€	700€
Application*	1100 hours	50€	55000€	Application	550 hours	50€	27500€
Waste consumption	11 tonn Garnet, Paint cans, brush, roll etc.	700€/tonn 50€	7750€	Waste consumption	Cartbord and foil	50€	50€
Personel	3-4 positions		68 days	Personel	2-3 positions		37 days
Personel accomodation, food and logistics.	4ea x 68 days	<u>200€</u>	54400€	Personel accomodation, food and logistics.	3ea x 37 days	<u>200€</u>	22200€
Sum:			<u>201150€</u>	Sum:			<u>131075€</u>

Does not include lifetime cost

sealforlife.com

Thank You



The most
dangerous phrase
in the language is "we've
always done it this way."

Rear Admiral Grace Hopper